

# MOAC-E-CSB-1

## Technical Datasheet for Motor and Blind Controller



### Description

The MOAC-E-CSB-1 is a 3-wire AC motor controller with Casambi integration.

The controller is calibrated within the software to set the upper (open) and lower (closed) limits, then using the integral timer movement, the shade can be set anywhere within the limits.

- AC Motor Control
- Single Channel
- Casambi Enabled
- Wireless Beacons
- Can be used with momentary switch



## Technical Specifications

### Mechanical

Housing	Black Plastic Injection Moulded ABS
Dimensions	162.2mm x 35mm x 33.3mm
Weight	112g
Protection	IP20
Mounting	Screwdown

### Input

Voltage Range	120-277VAC
Frequency	50-60Hz
Max. Mains Current	20mA (excluding relay outputs)
No-load Standby Power	<800mW

### Output

Output Voltage	120-277VAC
Max. Continuous Current per Relay	5A
Max. Inrush Current per Relay	165A/20ms

### Radio Transceiver

Operating Frequencies	2.4Ghz - 2.483Ghz
Maximum Output Power	+4dBm
Wireless Protocol	Casambi Wireless Mesh

### Operating Conditions

Ambient Temperature	0°C to +50°C
Max. Case Temperature	+75°C
Storage Temperature	-40°C to +80°C
Max. Relative Humidity	80% non-condensing

### Connectors (UP/DOWN INPUT) \*See note

Wire Range	0.2mm - 2.5mm
Wire Strip Length	8mm

### NOTE

Warning! UP/DOWN inputs are at line voltage. Appropriate wiring must be used. Switch current <1mA.

## Dimensions

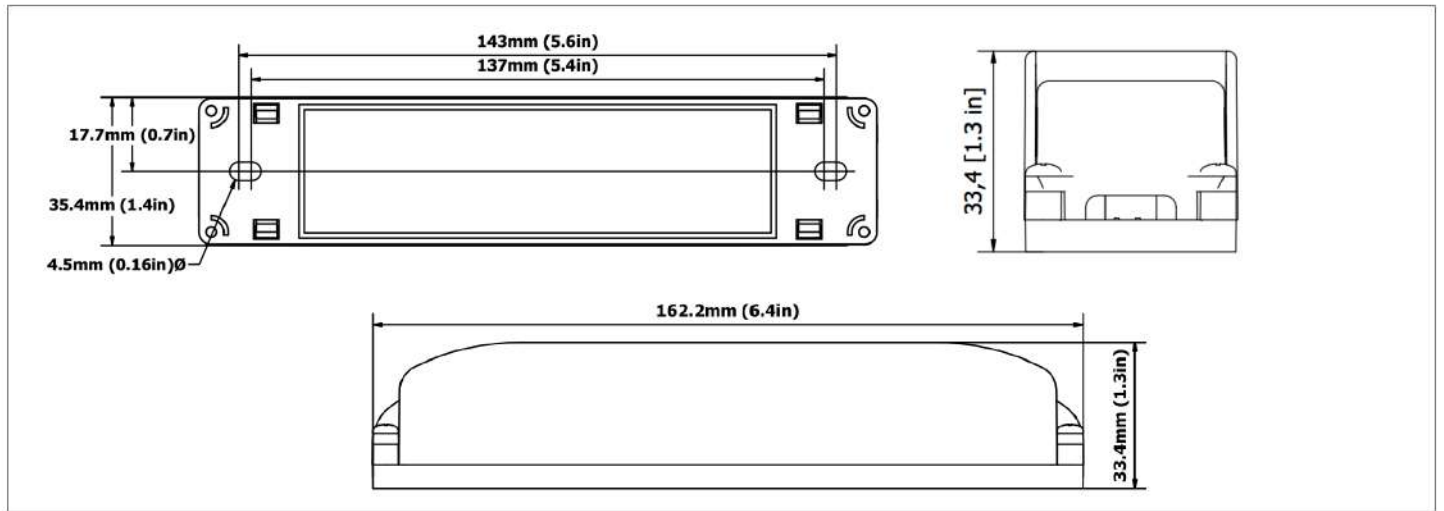

## Wiring Diagram

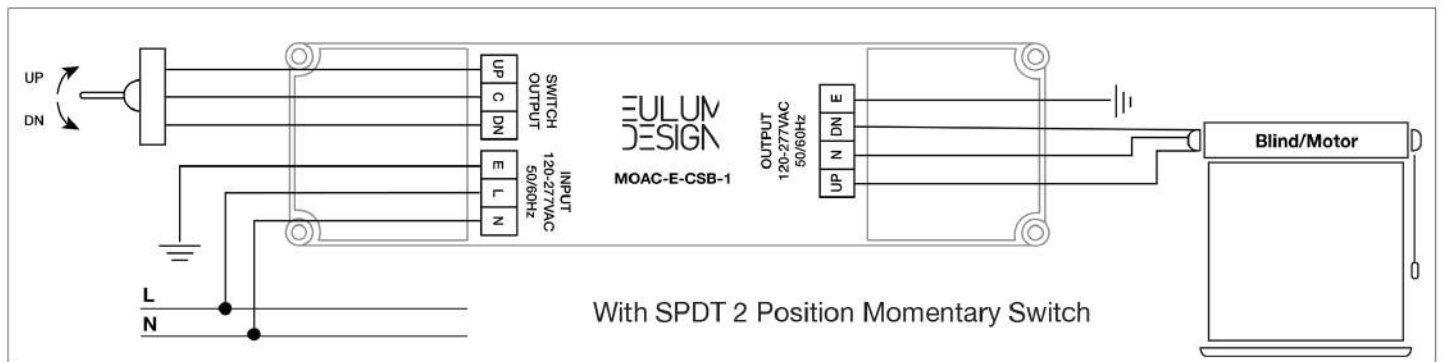
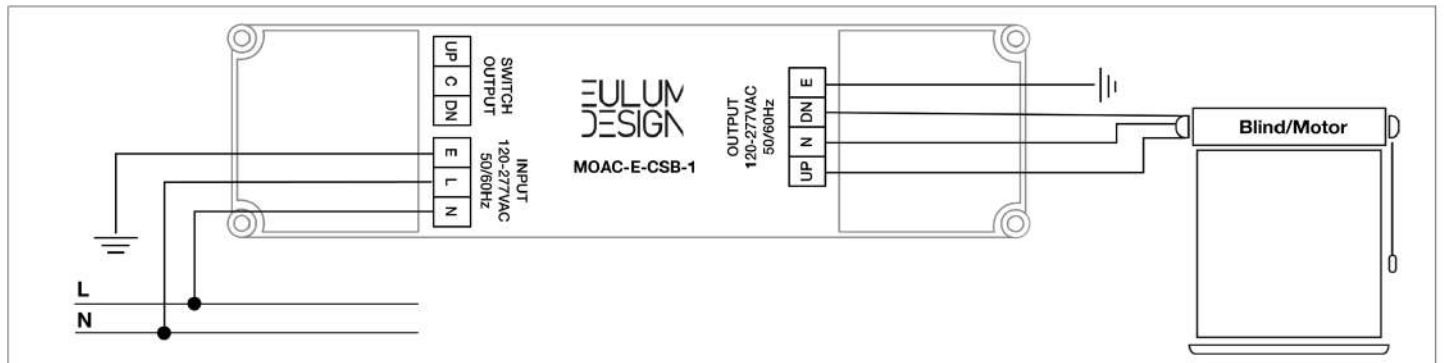

## Range

In open air, the wireless range can reach up to 75m. This will be reduced when placed inside a building. Please note that putting the unit inside a metal enclosure is unadvised as this will dramatically reduce the signal range.

## Compatible Devices:

iPhone iOS and later are supported  
 iPad iOS 10 and later are supported  
 Android 4.4 version (KitKat) and later are supported.



# Profiles

Profile Name	Description
MOAC-E-CSB-1	Blind controller, slider & jog buttons. Mode selection includes manual mode.
MOAC-E-CSB-1M	Blind controller, switches and jog buttons only. Mode selection includes manual mode. (switch)
Version	Evolution

# Calibration



1. Power on the device and open the Casambi App, select “Nearby devices”.



2. Tap “Nearby Devices”

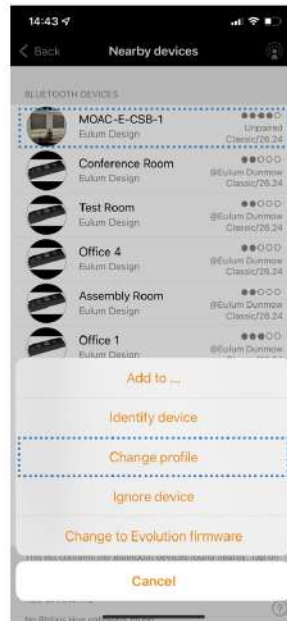

2. Tap the MOAC and then “Change profile”.



4. Choose your desired profile. MOAC-E-CSB-1 is the standard profile and will not show.



NOTE: The MOAC must be unpaired to change the profile. To unpair, double tap the MOAC-E-CSB-1 in the network and scroll to the bottom of the options to “Unpair Device”, then follow step on from Step 1 above.

# MOAC-E-CSB-1 Calibration Guide

## Upper & Lower Limits Tog Setup

There are 3 modes in the Parameters Menu:

0=RUN	Run Mode, should be selected after Calibration is done.
1=CAL	Calibration Mode, which is where the up/down limits are set
2=MAN	Manual Mode, meaning no limits are set and the blind must be watched and manually stopped when moving up/down every time it is used.

To set upper and lower limits, follow the below instructions:



1. Double tap the MOAC icon



2. Tap on "Set Mode"



3. Enter 1, for Calibration Mode



4. Hold down on the MOAC icon



5. Watching the blind, hold the "DOWN" button and release when the blind reaches your required lower limit



6. Hold the 'UP' button immediately after step 5 and release when the blind has reached the upper limit. The blind is now calibrated.



7. Double tap on the MOAC icon and tap on "Set Mode" again. Change to "0" for Run mode and you're good to go!  
On the blind slider, 0% will represent your upper limit, and 100% will represent your lower limit.

**NOTE: When in calibration mode, after setting the upper limit do not toggle down until you have gone back into parameters and set into Run Mode, otherwise it will re-set the calibration.**